

SCHRÖDER
GROUP



MOTORIZED SHEAR
MHSU

The motorized shear MHSU

The motorized shear MHSU has been designed for processing sheet metal and plastics. This shear enables clear cuttings for your serial production without difficulties.



The MSHU with NC positioning gauge POS 100 and sheet support to the front



Standard: MSHU with rear guarding via 2-beam light barrier incl. side protectio grid

Experience gathered over decades is reflected in the technology and design of the shear, which is capable of cutting almost any metal and non-metal materials. With the aid of new design techniques, we are able to offer a tried and tested product incorporating state-of-the-art technology.

The slideway guided shear MHSU offers you an entry into motorized cutting. This machine is able to cut up to 4 mm thick sheets fast and clearly and is available with a working length up to 3200 mm.

Easy handling

The compact and clearly-arranged machine construction of the MSHU as well as its ergonomic design enable an easy operation without any particular previous knowledge. All controls and displays are arranged for the operator and can be found on the central control panel.

Standard equipment

MHSU	
	Manual back gauge 500 mm
	Hold-down device with hard rubber rail to protect polished sheets
	Telescopic support table
	All-steel blade, double-edged
	Adjustable angle gauge left and right with scale
	Milled grooves every 10 mm along the table, parallel to the blades
	Selector switch for single and continuous stroke
	Foot switch
	Anchor plates incl. dowels

Special equipment

MHSU	
Safety	Obligatory CE safety package rear guarding via 2-beam light barrier incl. side protection grid
Blades	Fine adjustment screws for material with less thickness 0.5 mm
	Blades designed for stainless steel
Others	<ul style="list-style-type: none"> - LED cutting edge illumination - Pneumatic hold-down device - Stroke counter (with POS 100 incl.) - Extended sheet chute to the front - Sheet chute on wheels, 4 steering castors, 2 lockable (for cuttings up to max. 500 mm, up to max. 200 kg) - Sheet stacking cart (without stacking sheet insets), usable for deposition to the front, optionally to the back with 4 steering castors, lockable (for cuttings up to max. 750 mm, up to max. 500 kg, only in connection with sheet support) - Set of sheet metal plates for sheet stacking cart - Sheet support see p. 7 under gauges
Gauges	see p. 7
Tables	see p. 7



Sheet chute on wheels with 4 steering castors



Sheet stacking cart, usable for deposition to the front, optionally to the back with sheet metal plates

The right options for each task

The Schröder-shear is not just a productivity gain with its standard equipment, but its various options increase your efficiency additionally.

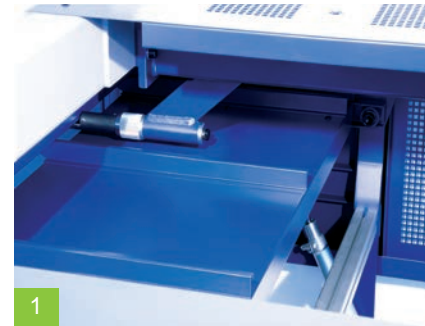
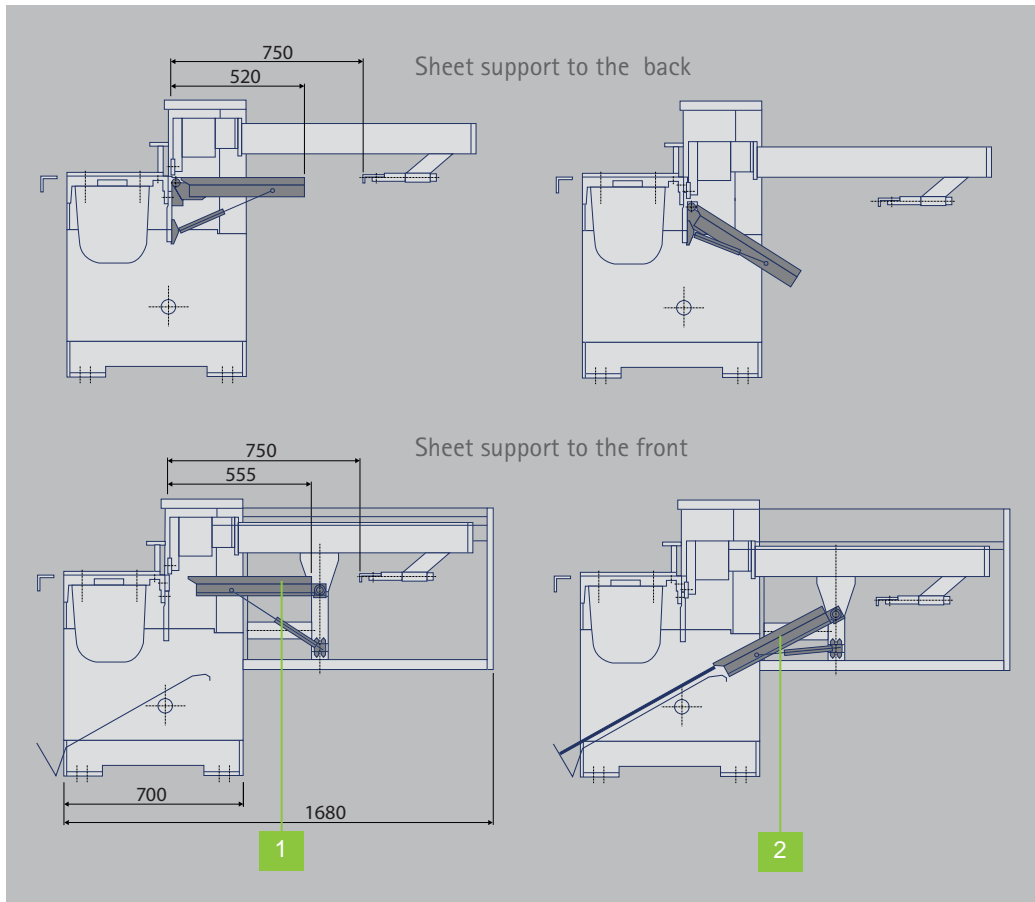

Sheet support to the front in horizontal position

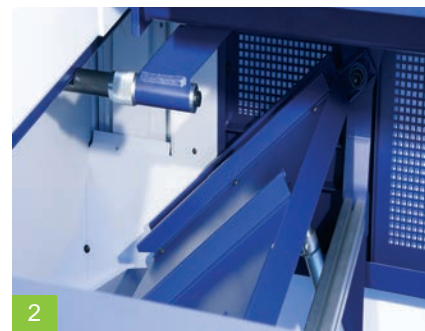

Sheet support to the front in tilted position, pneumatically controlled, incl. sheet chute, gauge width 750 mm or 1000 mm

High rigidity already in its basic configuration

The motorized shear MHSU is based on a torsion-free rigid welded construction and a powerful dynamic low-noise geared motor. The high static and dynamic rigidity are guaranteed thanks to sturdy key components such as cutting beam, sheet support table, lateral frames and main drive units.

The generously designed flat cutting beam guides dispose of robust and wear-resistant special sliding covers. This maintenance free sliding cover ensures optimum guidance and dampening characteristics.

Efficient sheet support

The sheet support holds the sheet upwards and leads the sheet in horizontal position to the gauge. After a successful cut the sheet will be deposited to the back or to the front.

In its standard configuration, the sheet support to the front is provided with an integrated sheet chute. In addition to that you can acquire a sheet chute on wheels or a sheet stacking cart (see pictures p. 3) - the latter one is also available for the sheet support to the back.

Gauge options and further possibilities

Thanks to the different gauge options multiple sheet formats can be cut by the MHSU which guarantees an optimal processing of your product.



Manual back gauge



Manual back gauge, adjustable from the front, with digital readout

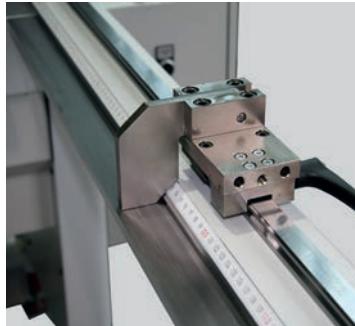

Extended angle gauge on the right with scale incl. lateral flip gauge on linear guide

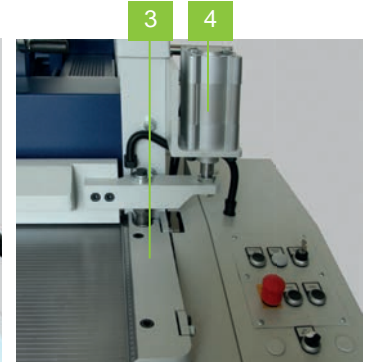

[3] Adjustable angle gauge
[4] Pneumatic hold-down device



Control panel POS 100 software control

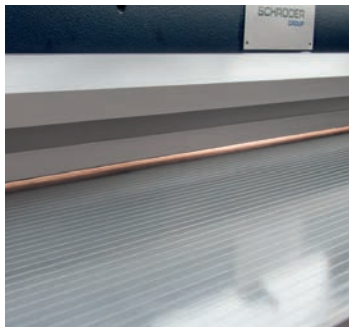

Cutting edge illumination

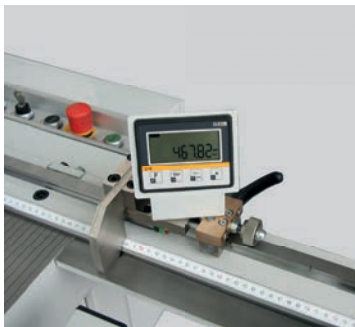

Optional: Extended angle gauge on the right with electronic length measurement system incl. lateral flip gauge on linear guide



Movable sheet support with T-slots on linear guide



The control panel (left) is directly mounted on the control cabinet and clearly-arranged for all control elements:

- Cut counter (special equipment)
- Indicator lamp
- Selector switch for single and continuous stroke
- Lift button
- EMERGENCY STOP button
- START button

Optimized cutting performance through inclined cutting beam

The cutting beam of the MHSU 3200 mm has been constructed and improved with the finite-element-method and thus ensures a precise cut of slim sheets with this working length.

Exact positioning

As the only manufacturer we are offering an adjustable angle gauge for our shears. Thus we grant an exactly right-angled positioning of the sheet.

On request this angle gauge can be exchanged quickly. As an extra feature the extended angle gauge is also available with a flip gauge and / or an electronic length measurement system.

Technische Daten

MHSU	1,000	1,250	1,500	2,000	2,500	3,200
Working length	1,030 mm	1,280 mm	1,530 mm	2,030 mm	2,530 mm	3,230 mm
Sheet thickness (400 N/mm ²)	2.5/3.5/4.0 mm	3.0 mm	2.0/3.5/4.0 mm	2.5/3.0 mm	2.0/2.5 mm	1.5/2.0 mm
Cutting angle	2.4°	2.0°	2.7°	2.0°	1.7°	1.3°
Number of strokes (per min.)	34					
Driving power	2.5/3.4/3.4 kW	3.4 kW	2.5/3.4/4.0 kW	3.4/4.0 kW	3.4/4.0 kW	3.4/4.0 kW
Weight basic machine (ca.)	720/780/850 kg	790 kg	730/850/940 kg	960/1,290 kg	1,140/1,350 kg	1,460/1,790 kg
Outer dimensions						
(a)	1,120 mm	1,370 mm	1,620 mm	2,120 mm	2,620 mm	3,320 mm
(b)	1,220 mm	1,470 mm	1,720 mm	2,220 mm	2,720 mm	3,420 mm
(c)	1,600 mm	1,850 mm	2,100 mm	2,600 mm	3,100 mm	3,800 mm
Back gauge, manual 500/750/1,000 mm (d)	1,980 mm					
Back gauge, motorized 750 mm (d)	1,980 mm					
Back gauge, motorized, 1,000 mm (d)	2,080 mm					
MHSU with sheet support to the front: Outer dimensions						
(a)	1,120 mm	1,370 mm	1,620 mm	2,120 mm	2,620 mm	3,320 mm
(b)	1,220 mm	1,470 mm	1,720 mm	2,220 mm	2,720 mm	3,420 mm
Back gauge, manual (c)	1,500 mm	1,750 mm	2,000 mm	2,500 mm	3,000 mm	3,700 mm
Back gauge, motorized (c)	1,575 mm	1,825 mm	2,075 mm	2,575 mm	3,075 mm	3,775 mm
Back gauge, manual, sheet support to the front with protection grid 750 mm (d)	1,680 mm					
Back gauge, POS 100, sheet support to the front with protection grid 750 mm (d)	1,800 mm					
Back gauge POS 100, sheet support with protection grid 1,000 mm (d)	2,050 mm					

Without sheet support

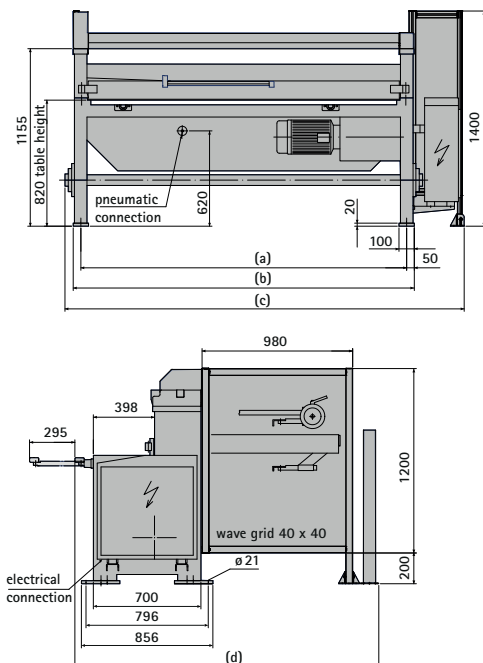

Sheet support to the front

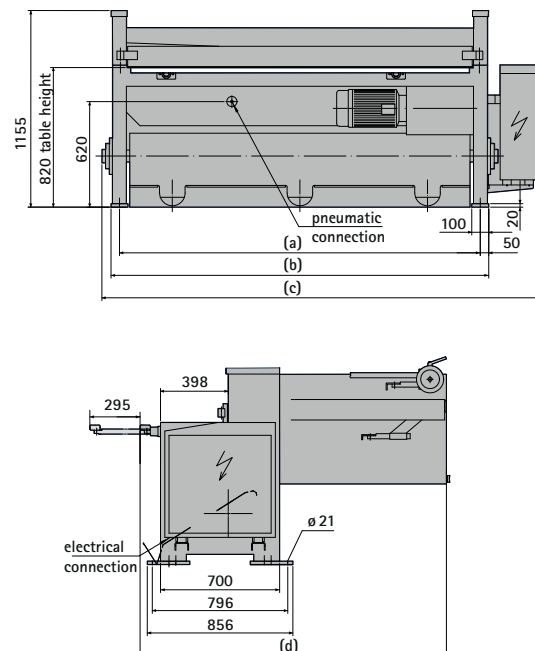

All dimensions in mm

Gauges and table variants

Special equipment

MHSU	
Gauges	Manual back gauge 750 mm / 1,000 mm
	Manual back gauge 750 mm / 1,000 mm, adjustable from the front, with digital readout
	NC positioning gauge POS 100 with 9-step program 750 mm / 1,000 mm
	Sheet support, pneumatically controlled, to the back
	Sheet support, pneumatically controlled, to the front incl. sheet chute
	Sheet support to the front, with gauge extension up to 1000 mm
Tables	2 sheet support arms with T-slot incl. scale (standard teleskop table is dropped) - 1,000 mm - 1,500 mm - 2,000 mm incl. foot rest
	Extended angle gauge (right or left) with scale - 1,000 mm - 1,500 mm - 2,000 mm incl. foot rest
	Extended angle gauge (right or left) with scale incl. lateral flip gauge on linear guide - 1,000 mm - 1,500 mm - 2,000 mm incl. foot rest
	Extended angle gauge (right or left) with electronic length measurement system, fine adjustment and lateral flip gauge on linear guide - 1,000 mm - 1,500 mm - 2,000 mm incl. foot rest
	Adjustable angle gauge with scale division 0 - 180°
	T-slot in table 400 mm
	Tipping gauge for insertion in T-slot
	Linear guide at the front for movable table support arms (without support arms)
	Movable support arm for linear guide, at the front, incl. T-slot and scale - 1,000 mm - 1,500 mm - 2,000 mm incl. movable foot rest

All specifications are considered as guidelines and may be subject to changes at any time.

Standard colours: RAL 7035 light grey, RAL 5003 sapphire blue. Special painting at an extra charge



Schröder Group

The Schröder Group consists of Hans Schröder Maschinenbau GmbH, which is located in Wessobrunn, Germany, and SCHRÖDER-FASTI Technologie GmbH, which is located in Wermelskirchen, Germany.

Founded in 1949, Hans Schröder Maschinenbau GmbH unifies traditional and modern approaches in machine building: Successfully managed as a quality and customer-oriented, family-owned company, Hans Schröder Maschinenbau is specialized in the development of modern machine concepts for bending and cutting sheet metal.

The successful integration of the Fasti Company in 2006 and its worldwide presence make the Schröder Group one of today's leading providers of machines for bending, cutting, beading, flanging, and circular bending all types of sheet metal. The company's precision machines range from proven solutions for craftsmen to innovative, high-performance machines for automatic industrial production processes. Overall, the Schröder Group currently employs more than 240 people at various locations at home and abroad.

All information provided as a guide only
and subject to change at all times..
HSM 160115EN

Schröder Maschinenbau GmbH
Feuchten 2 | 82405 Wessobrunn-Forst | Germany
T +49 8809 9220-0 | F +49 8809 9220-700
E info@schroedergroup.eu
www.schroedergroup.eu

SCHRÖDER
GROUP